



ASA-RT s.r.l.

Strada del Lionetto 16/a, 10146 Torino, ITALY
 Tel +39 011 796333 - 720467 - FAX +39 011 712339
 E-Mail: info@asa-rt.com http:// www.asa-rt.com

LOAD CELL FOR ROLL / PULLEY
 MESSDOSE FÜR ROLLE / UMLENKROLLE

ATB - C

Data sheet C / 95 / 1 Datenblatt

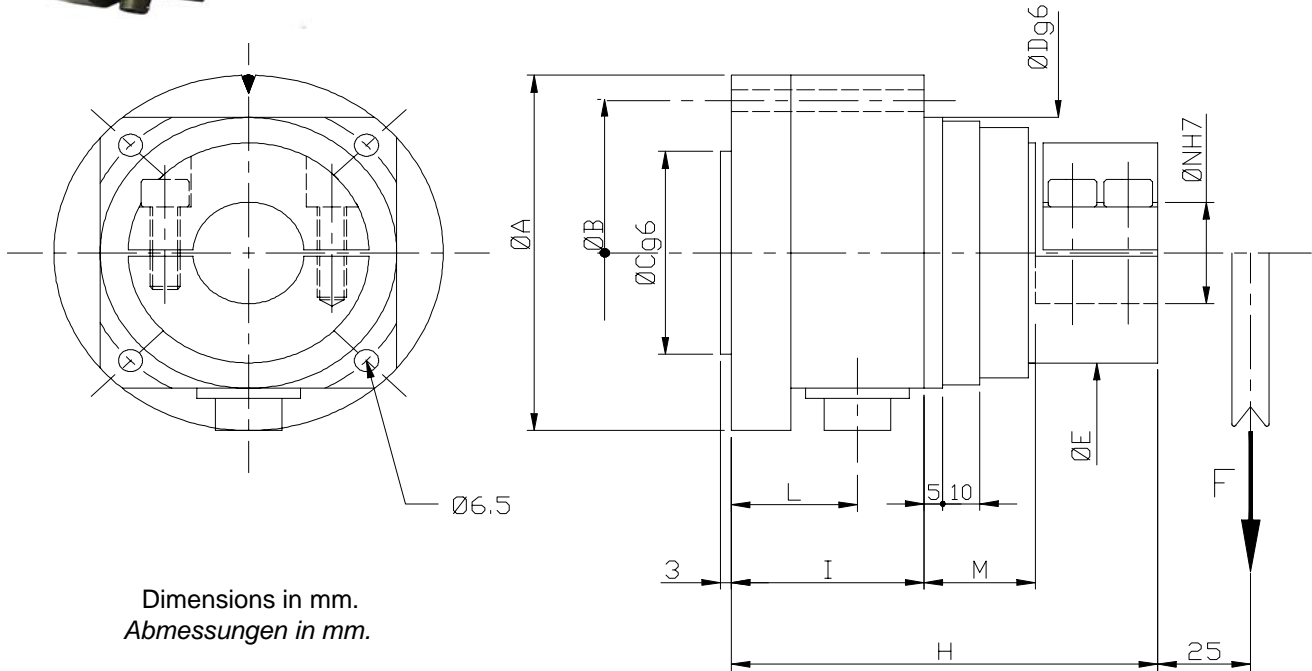

Dimensions in mm.
 Abmessungen in mm.

Type Typ	Nominal Force F Meßbereich F	A	B	C	D	E	H	I	L	M	N
ATB-C / 25	25 N	90	75	30	60	38	105	47	29	23	20
ATB-C / 50	50 N	90	75	30	60	38	105	47	29	23	20
ATB-C / 125	125 N	90	75	30	60	38	105	47	29	23	20
ATB-C / 250	250 N	105	90	60	80	65	115	52	34	30	30
ATB-C / 500	500 N	105	90	60	80	65	115	52	34	30	30

Technical Data	Technische Daten	
- Ultimate Load	> 500 % F	- Bruchlast
- Accuracy	0.2 % F	- Genauigkeit
- Sensitivity	1.5 mV / V	- Empfindlichkeit
- Repeatability (total error hysteresis and non-linearity)	< 0.3 % F	- Wiederholgenauigkeit (gesamt Hysteresis-Abweichung und Nichtlinearität)
- Zero bridge balance	±5 % F	- Nullpunktabweichung
- Temperature effect on zero	±0.1 % F / 10 °C	- Temperatureinfluß auf den Nullpunkt
- Temperature range	(+10 ...+60 °C) o (+10...+100 °C)	- Arbeitstemperaturbereich
- Bridge resistance	350 Ohm	- Brückenwiderstand
- Maximum supply voltage	12 Vdc	- Max. Speisespannung
- Protection Level	IP54	- Schutzgrad
- Material	Avional	- Material
- Connector "N"	IPT06A-8-4S-SRN436	- Anschlußstecker "N"
- Insulation resistance	> 10 Gohm	- Isolationswiderstand

**ASSEMBLING EXAMPLE
EINBAUBEISPIELE**

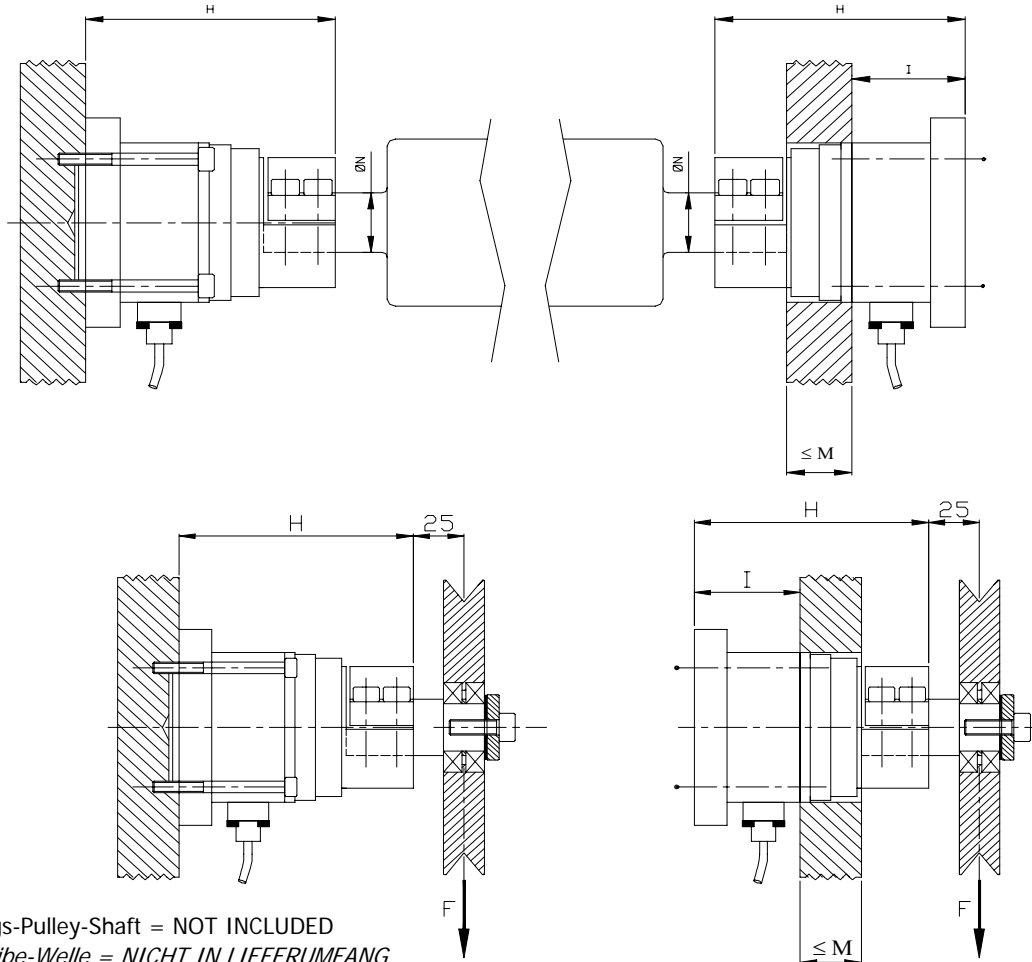

Ball-bearings-Pulley-Shaft = NOT INCLUDED
Lager-Scheibe-Welle = NICHT IN LIEFERUMFANG

**ELECTRICAL CONNECTION
ELEKTRISCHE ANSCHLÜSSE**

Connector (if supplied) Anschluß	Signal Names Signal- bezeichnung	Connection with 4 wires + shield * Anschluß mit 4 Adern + Abschirmung *	Connection with 6 wires + shield * Anschluß mit 6 Adern + Abschirmung *	Teflon cable with 7 wires + shield Teflonkabel mit 7 Adern + Abschirmung
A	EXC -	black / schwarz	brown / braun	yellow / gelb
A	SNS -		white / weiß	black / schwarz
B	SIG -	white / weiß	yellow / gelb	green / grün
C	EXC +	red / rot	grey / grau	brown / braun
C	SNS +		pink / rosa	red / rot
D	SIG +	brown / braun	green / grün	white / weiß
	SCH	shield / Abschirmung	shield / Abschirmung	shield / Abschirmung
	N.C.			grey / grau

* Color code used when the cable is also supplied by ASA-RT

**ORDER CODE
BESTELLCODE**

